

## 型号识别 Model identification

MP-100 R M G A R V 5

① ② ③ ④ ⑤ ⑥ ⑦ ⑧ ⑨

①系列代码 Series Symbol	MP
②规格 Specification	6,10,15,20 30,40,55, 70,100,120
③类型 Type	R:标准型Standard RZ:高扬程型High head RX:大流量型High capacity
④配管形式 Type of Connection	无标志:软管连接 M:G螺纹连接 U:由任 Non-code:means the ordinary type, M:means the thred mouthpiece U:Union

⑤泵体材质 Casing Material	G:GFRPP C:CFRPP P:PVDF E:CFRETFE
⑥泵轴材质 Shaft Material	A:高铝陶瓷CERAMIC S:碳化硅SSIC
⑦轴承材质 Bearing Material	C:碳CARBON R:填充四氟PTFE S:碳化硅SSIC
⑧O型圈材质 O-Ring Material	E:三元乙丙EPDM V:氟橡胶VITON
⑨频率 Frequency	无标志:普通50/60HZ No code: Nomal -5: 50HZ

## 性能曲线图 Performance curves

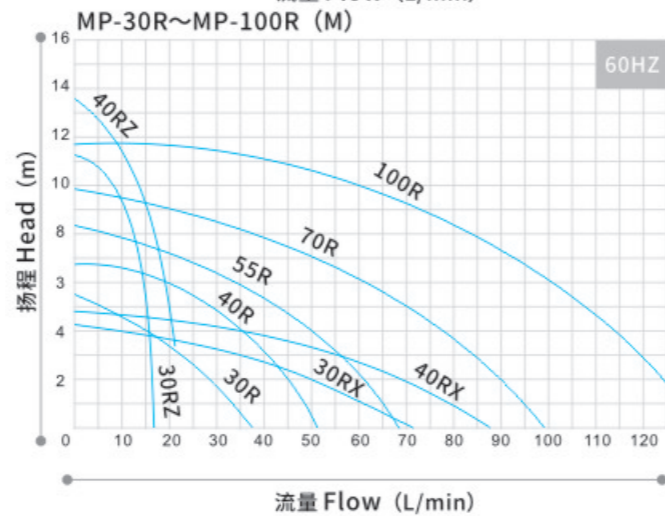
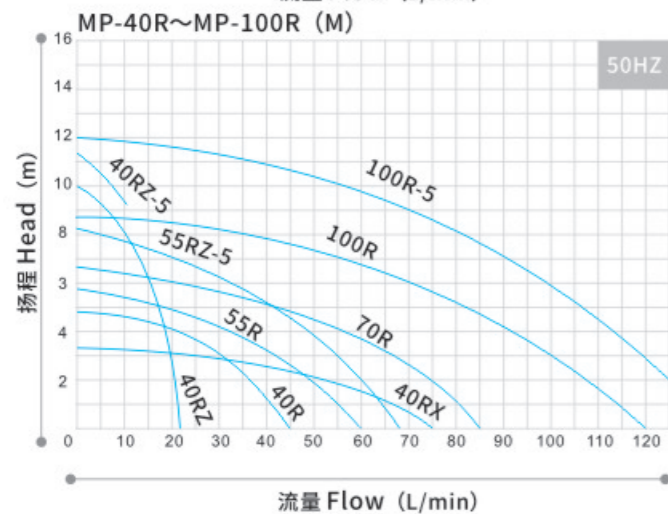
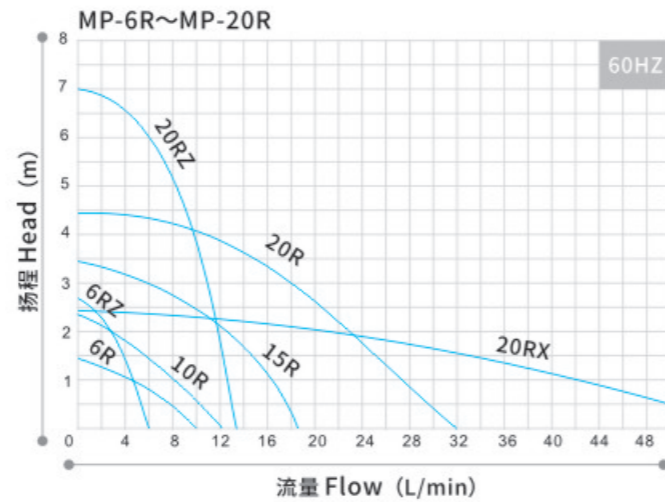
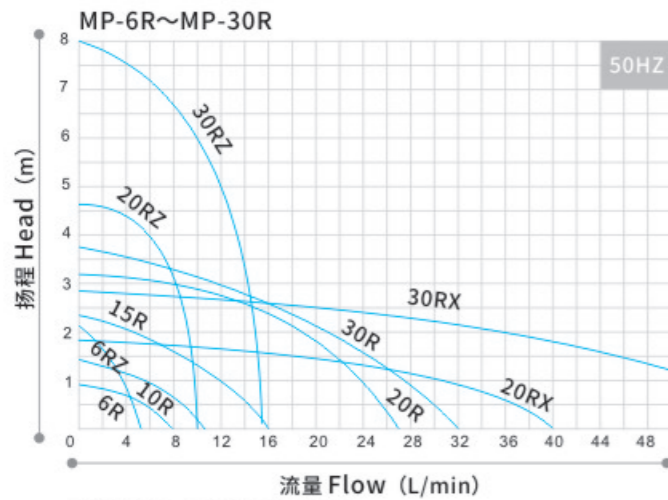

·性能曲线图为室温下输送清水时的表现。

·The performance curve is the performance of transferring clear water in room temperature.

## 外形尺寸图 Dimensional drawing, Part drawing

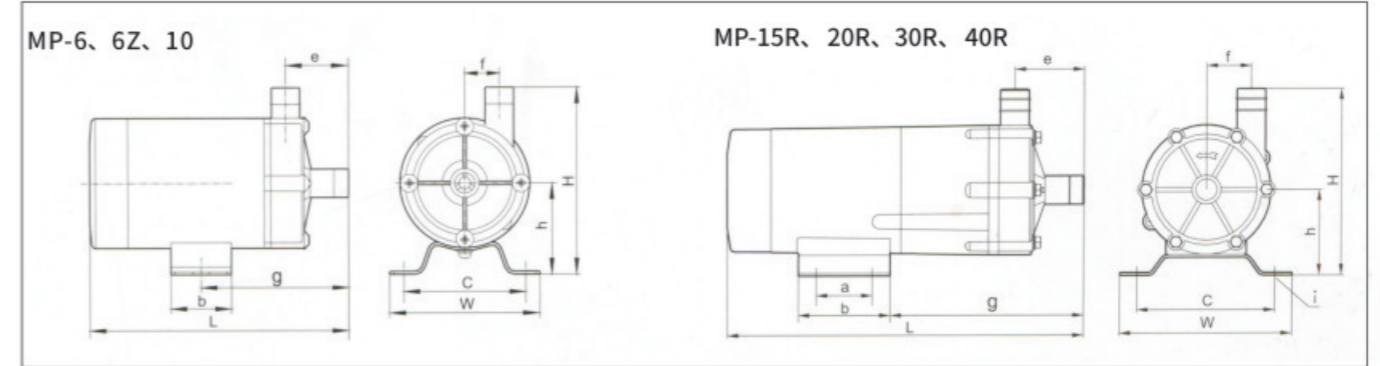

型号 Model	W	H	L	a	b	c	h	e	f	g	i	型号 Model	W	H	L	a	b	c	h	e	f	g	i
MP-6	74	83	129	30	60	36	31	17	74	2-Ø6		MP-15R	83	100	194	49	64	68	45	39	23	92	4-6x10
MP-6Z	74	83	129	30	60	36	31	17	74	2-Ø6		MP-20R	85	115	211	30	50	68	56	38.5	28.5	106	4-5.5x10
MP-10	74	83	129	30	60	36	31	17	74	2-Ø6		MP-30R	120	130	248	40	64	100	60	48	31	135	4-Ø9
												MP-40R	120	130	241	40	64	100	60	48	31	135	4-Ø9

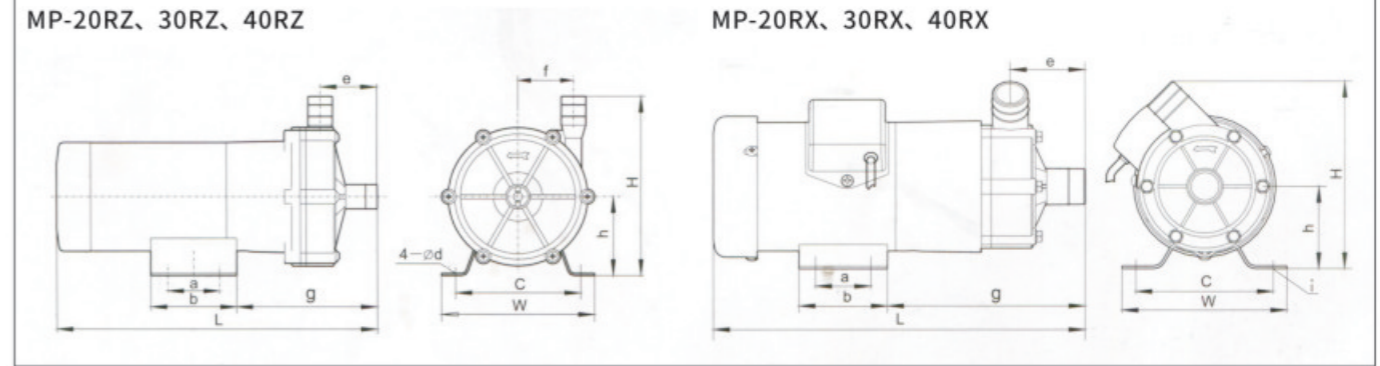

型号 Model	W	H	L	a	b	c	h	e	f	g	i	型号 Model	W	H	L	a	b	c	h	e	f	g	i
MP-20RZ	85	126	212	30	50	68	56	40	40	109	4-5.5x10	MP-20RX	85	130	220	30	50	68	56	46.5	-	118	4-5.5x10
MP-30RZ	120	130	234	40	64	100	60	40	40	120	4-Ø9	MP-30RX	120	137	257	40	64	100	60	54	-	137	4-Ø9
MP-40RZ	120	150	241	40	64	100	60	40	45	128	4-Ø9	MP-40RX	120	140	269	45	75	100	64	54	-	143	4-9x14

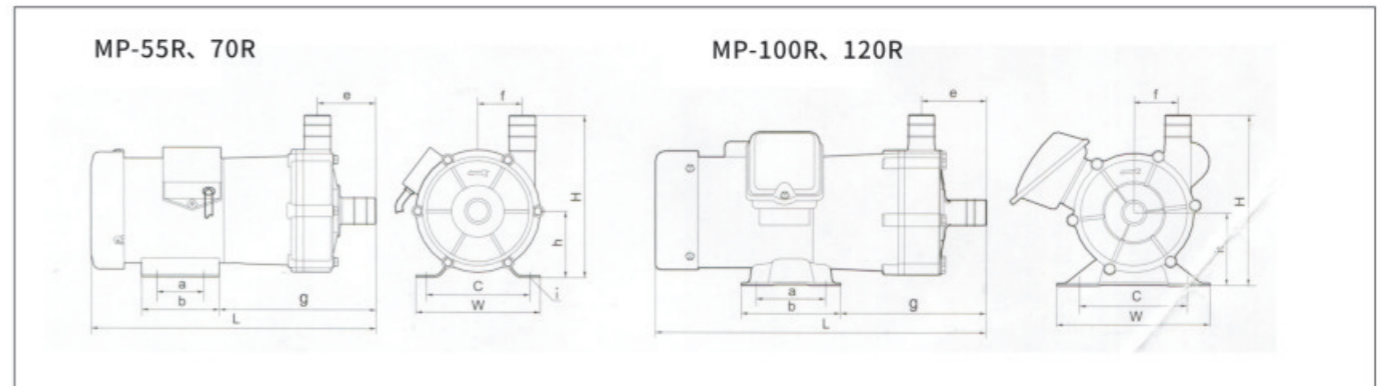

型号 Model	W	H	L	a	b	c	h	e	f	g	i	型号 Model	W	H	L	a	b	c	h	e	f	g	i
MP-55R	120	158	277	45	75	100	65	56.5	43	152	4-9x14	MP-100R	156	174	335	70	100	110	74	65.5	44	147	4-9x27
MP-55R-5	120	158	277	45	75	100	65	56.5	43	152	4-9x14	MP-100R-5	156	174	335	70	100	110	74	65.5	44	147	4-9x27
MP-70R	143	158	286	70	96	108	65	56.5	43	135	4-9x22	MP-120R	140	210	369	98	128	110	95	80	51	120.5	4-Ø12